



**Montage porte avec serrure à rouleau**  
profils porte ouvrante **40 - 40**



- Porte battante avec Profils porte ouvrante **40 / 40**
- Serrure à rouleau seule ou serrure à rouleau avec pêne dormant
  - Demi-cylindre 10x35 (ovale) avec 3 clés
  - Poignée de tirage

Fermeture à clé **SEULEMENT** côté charnière avec le pêne demi-cylindre

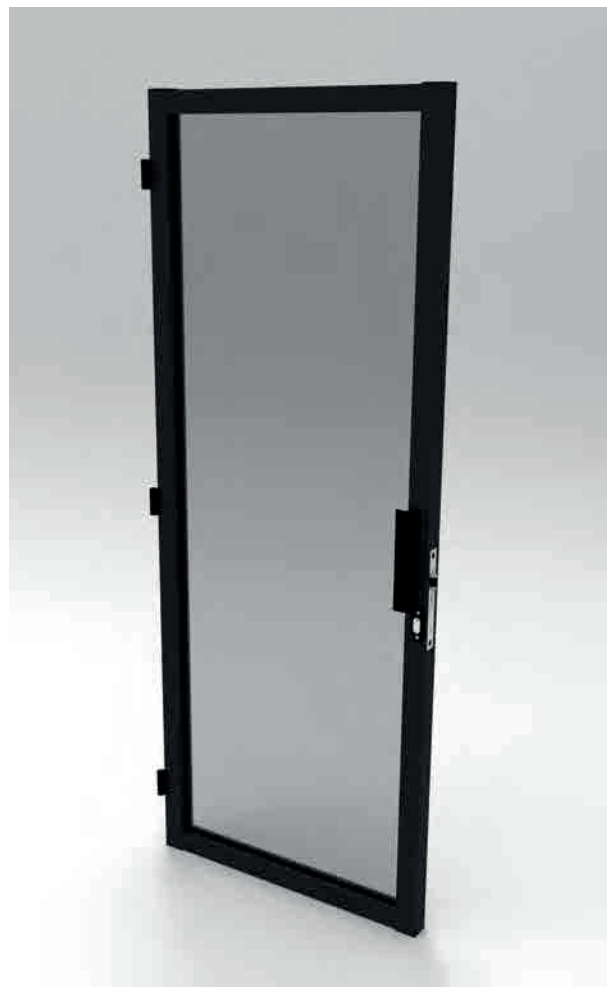

**Montage porte avec béquille**  
profils porte ouvrante **40 - 66**

- Porte battante avec Profils porte ouvrante **40 / 66**
- Serrure pêne 1/2 tour et pêne dormant
  - Cylindre entier 35x35 (européen) avec 3 clés
  - Béquilles + rosaces ovales

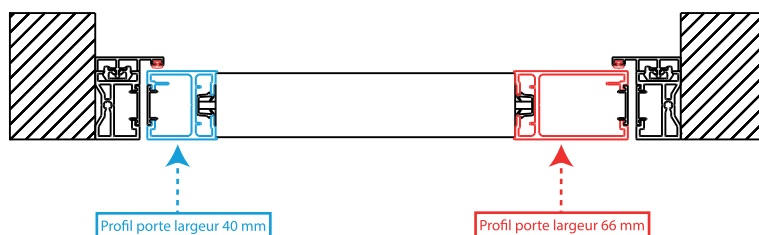

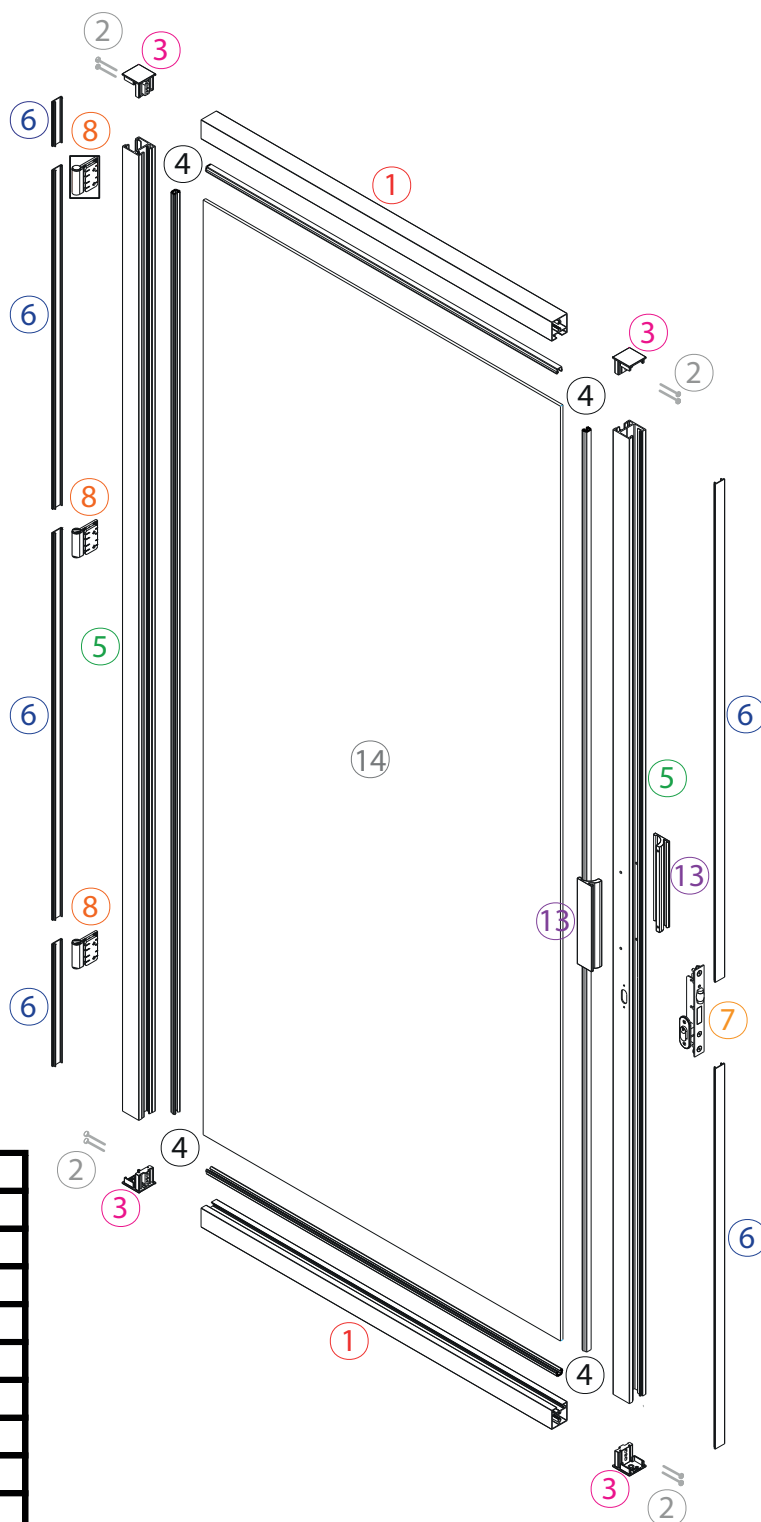
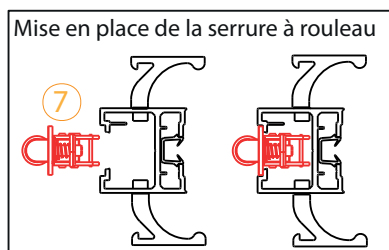
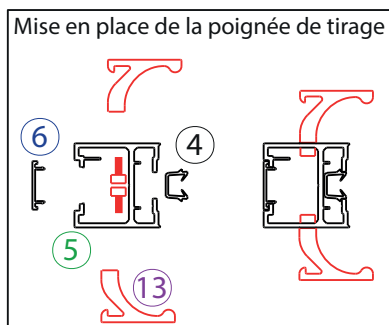
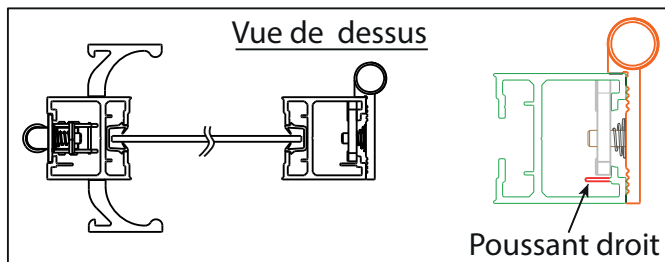
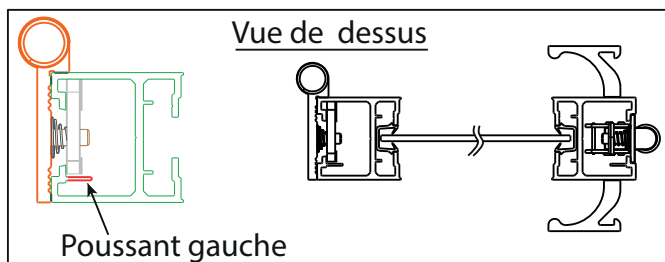

N°	Qté	Désignation
1	2	Profil traverse haute et basse 40
2	8	Vis 4,8x50 auto foreuse
3	4	Capot d'assemblage porte ouvrante 40
4	4	Profil de vitrage 6/8
5	2	Profil porte ouvrante 40
6	6	Profil plat de finition 23
7	1	Serrure à rouleau avec pêne + demi-cylindre
8	3	Paumelle supérieur
13	2	Poignée de tirage + vis
14	1	Remplissage 6/8

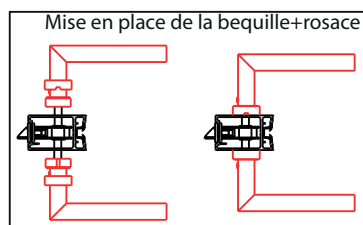
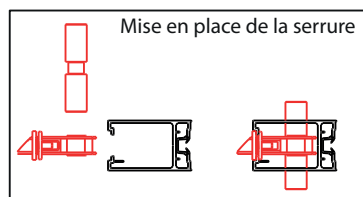
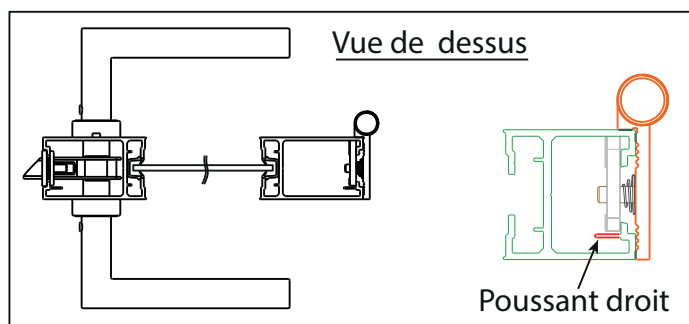
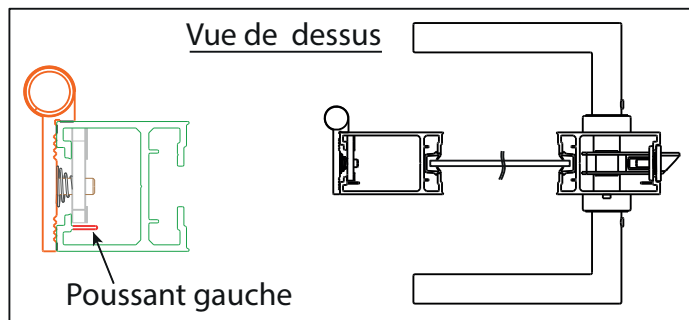

N°	Qté	Désignation
1	2	Profil traverse haute et basse 40
2	8	Vis 4,8x50 auto foreuse
3	2	Capot d'assemblage porte ouvrante 40
3 bis	2	Capot d'assemblage porte ouvrante 66
4	4	Profil de vitrage 6/8
5	1	Profil porte ouvrante 40
5 bis	1	Profil porte ouvrante 66
6	6	Profil plat de finition 23
7	1	Serrure pêne demi-tour + cylindre
8	3	Paumelle supérieur
13	2	Béquille + Rosace ovale
14	1	Remplissage 6/8

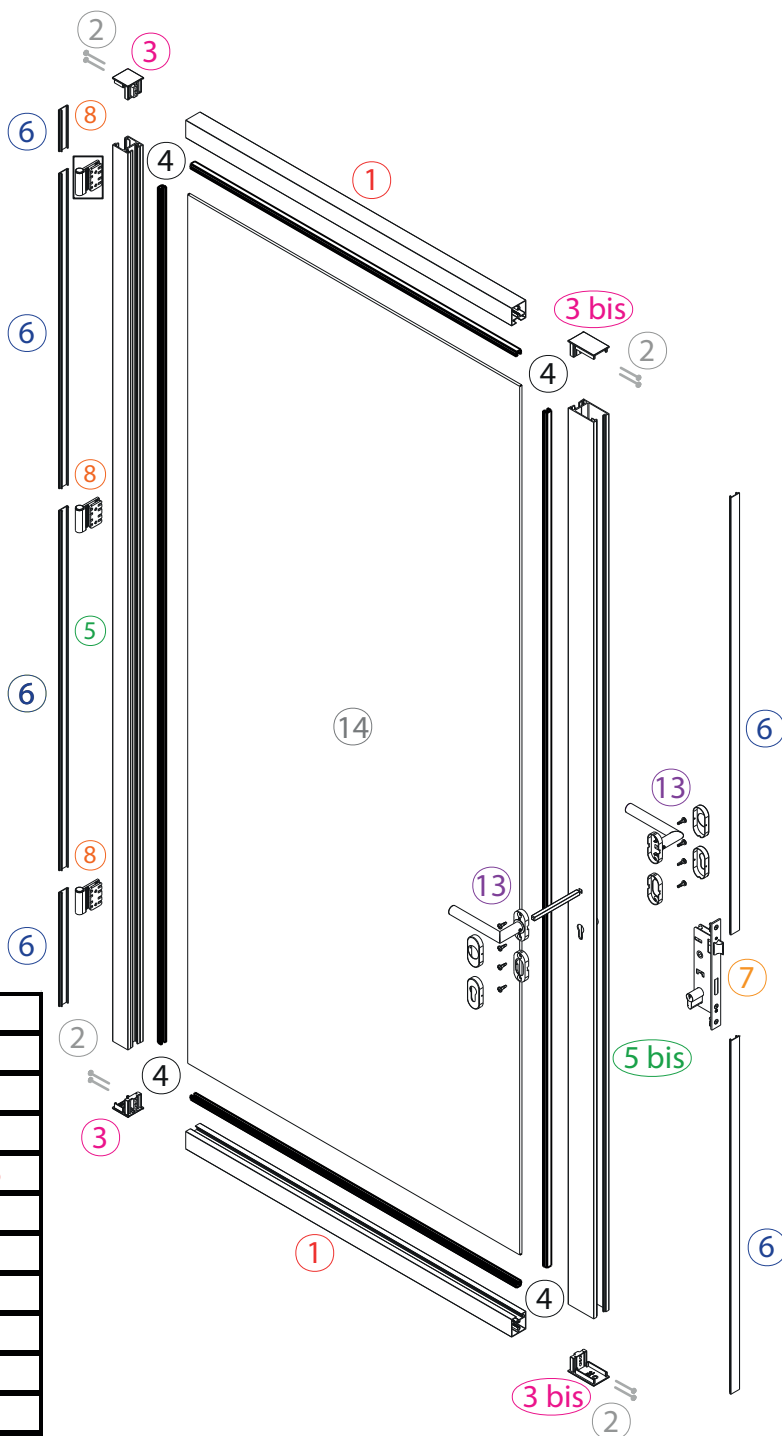

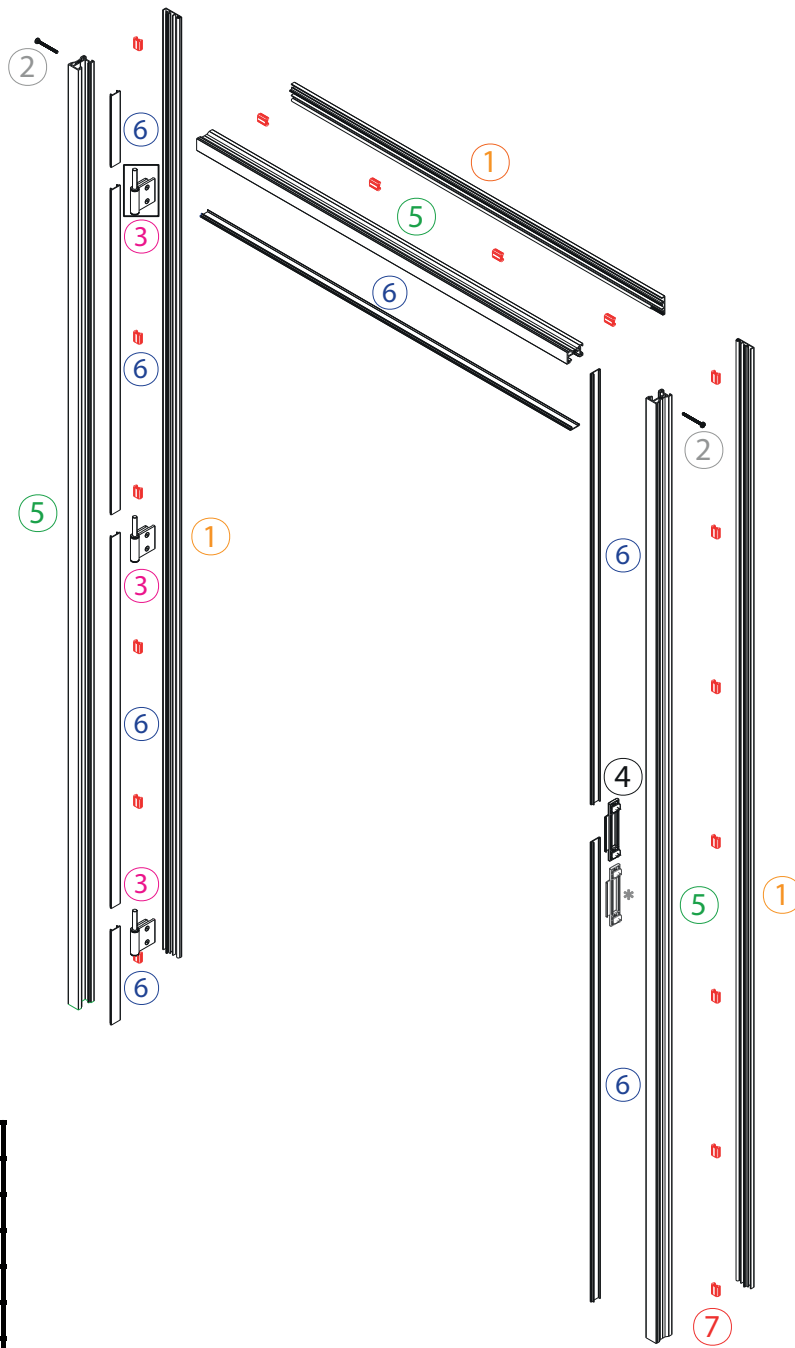
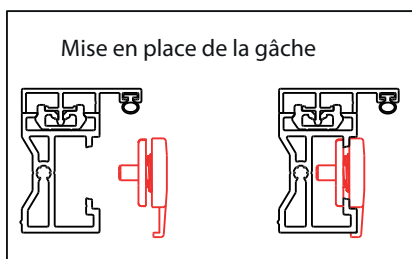
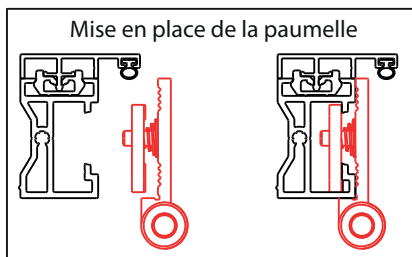
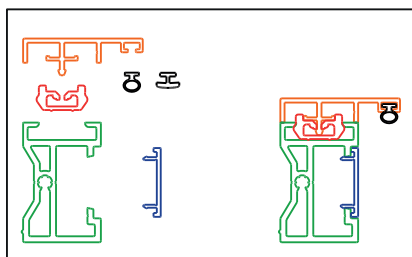

N°	Qté	Désignation
1	3	Profil parclose dormant 26
2	2	Vis 4,8x50 auto foreuse
3	3	Paumelle inférieur
4	1*	Gâche de fermeture
5	3	Profil dormant 26
6	7	Profil plat de finition 23
7	18	Clips

\* 2 gâches si serrure avec pêne demi-tour et dormant (béquille)



<b>PROFIL DORMANT 26</b>		<b>PAUMELLE COMPLETE</b>	
<b>PROFIL PARCLOSE DORMANT 26</b>		<b>SERRURE A ROULEAU SEUL OU + PENE + 1/2 CYLINDRE</b>	
<b>PROFIL PORTE OUVRANTE 40</b>		<b>SERRURE AVEC PENE + CYLINDRE</b>	
<b>PROFIL PORTE OUVRANTE 66</b>		<b>POIGNEE DE TIRAGE - 180MM</b>	
<b>PROFIL TRAVERSE HAUTE ET BASSE 40</b>		<b>BEQUILLES + ROSACES</b>	
<b>PROFIL TRAVERSE INTERMEDIAIRE 28</b>		<b>CLIPS</b>	
<b>PROFIL PLAT DE FINITION 23</b>		<b>GACHE DE FERMETURE</b>	
<b>PROFIL DE VITRAGE 6/8</b>		<b>CAPOT D'ASSEMBLAGE PORTE OUVRANTE 40</b>	
<b>JOINT D'ETANCHEITE DORMANT</b>		<b>CAPOT D'ASSEMBLAGE PORTE OUVRANTE 66</b>	
<b>VIS 4,8X50 AUTO-FOREUSE (Embout PH2)</b>		<b>VERROU A ONGLET</b>	



Dimensions Maxi porte simple  
Profil 40 ou 66

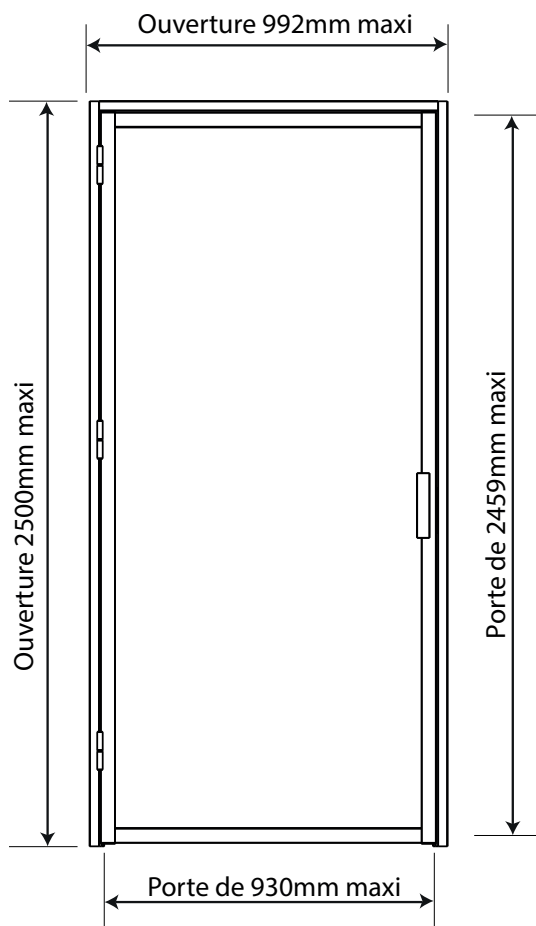

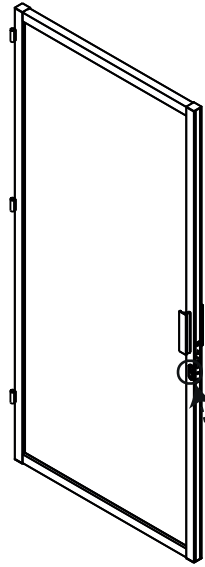
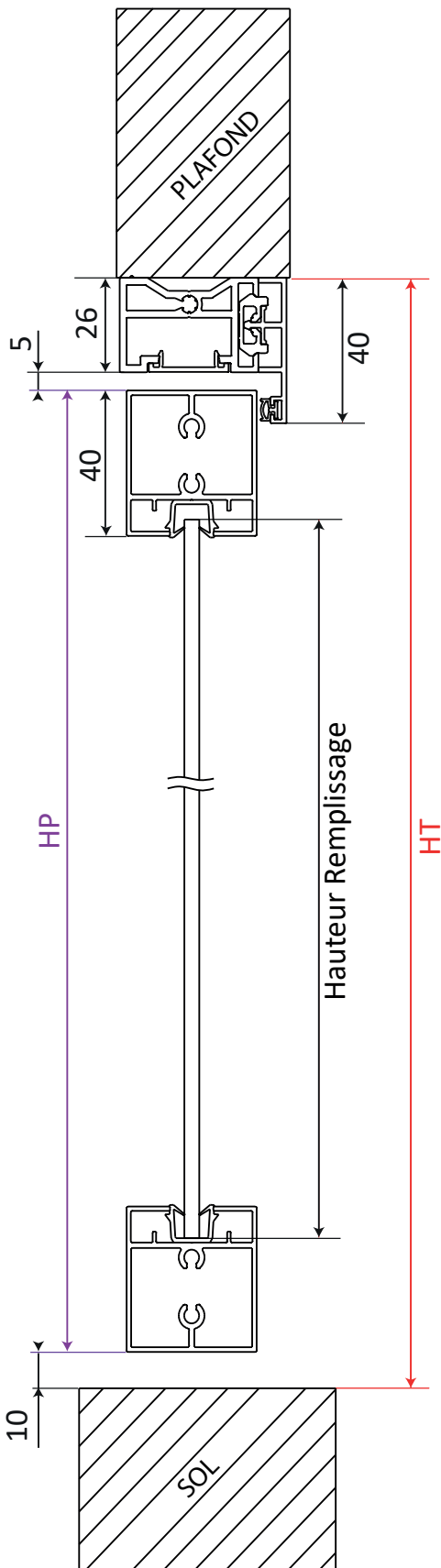

**Montage porte avec serrure à rouleau**  
**Profils 40-40**

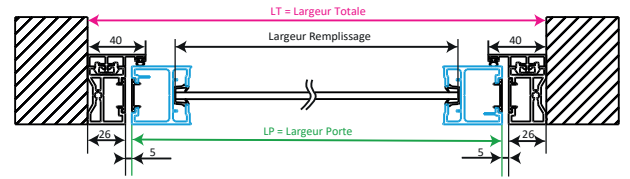
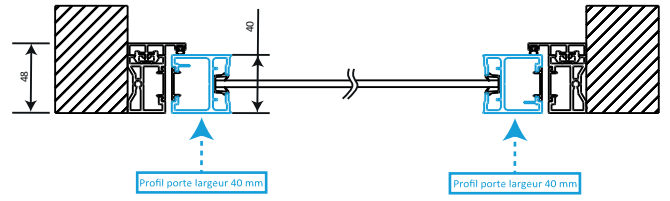

- Porte battante avec profils porte 40 / 40
- Serrure à rouleau
  - ou
  - Serrure à rouleau + pêne demi-cylindre (fermeture à clé côté charnière)
  - poignée de tirage

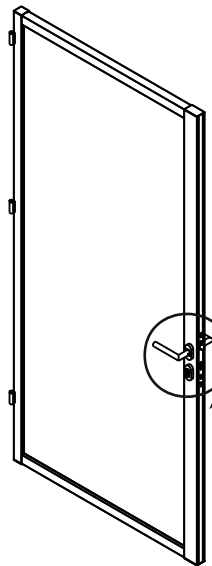

**Montage porte avec béquille**  
**Profils 40-66**

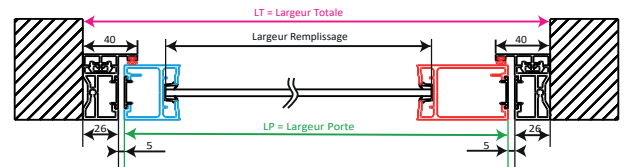
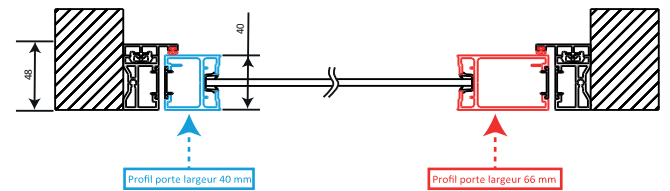

- Porte battante avec profils porte 40 / 66
- Serrure pêne 1/2 tour et pêne dormant
  - cylindre entier 35x35 avec 3 clés
  - béquilles + rosaces ovales

ou

- Porte battante avec profils porte 40 / 40
- Serrure à rouleau
  - ou
  - Serrure à rouleau + pêne demi-cylindre (fermeture à clé côté charnière)
  - poignée de tirage



## Largeur Remplissage

Profils 40-40



$$\text{Largeur Remplissage} = LP - 62$$

Profils 40-66

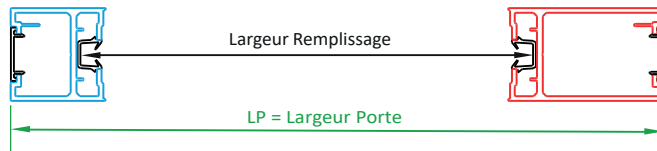

$$\text{Largeur Remplissage} = LP - 88$$

## Hauteur Remplissage (selon la hauteur sous-traverses)

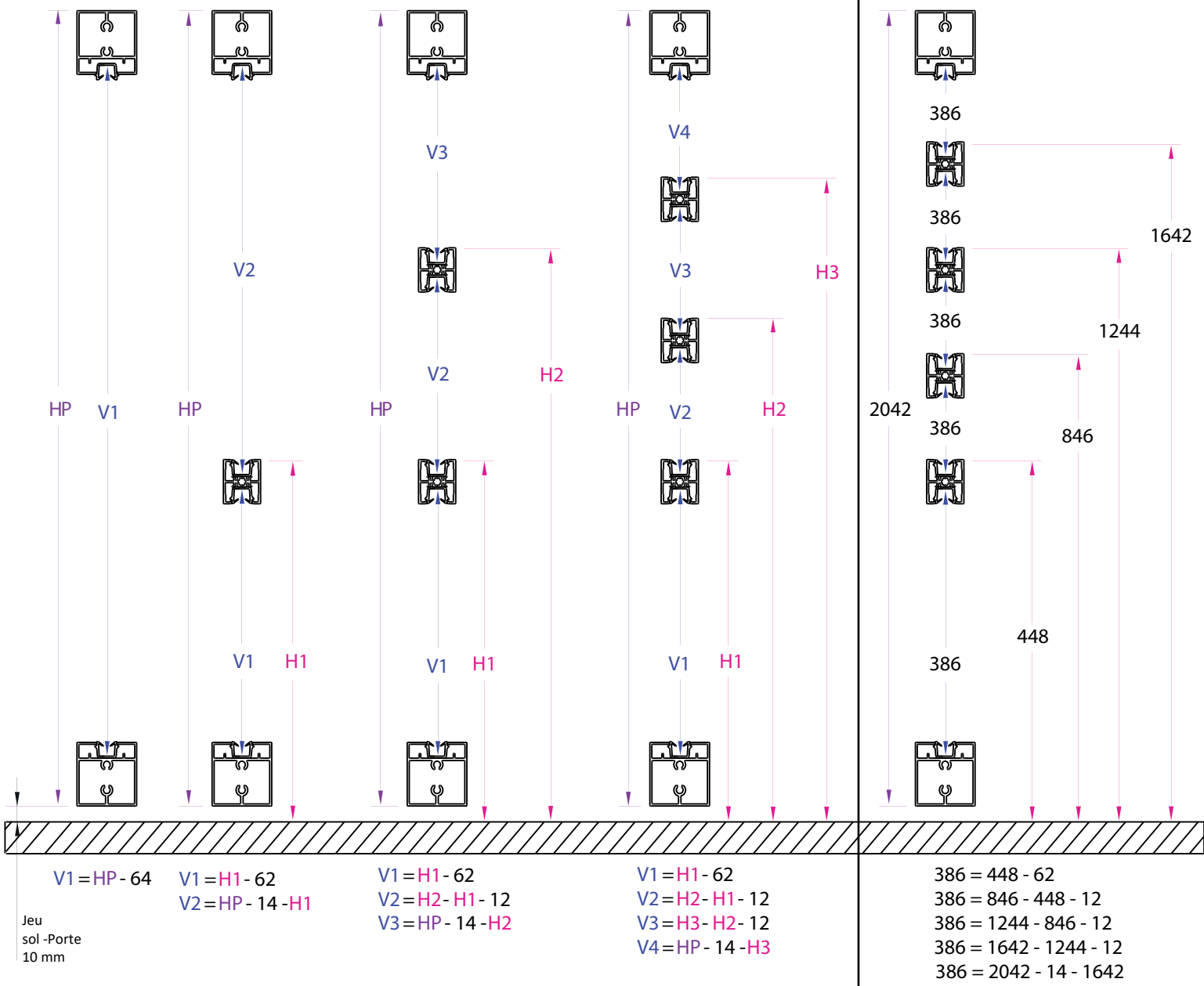





1 - Mise en place des **paumelles inférieures**

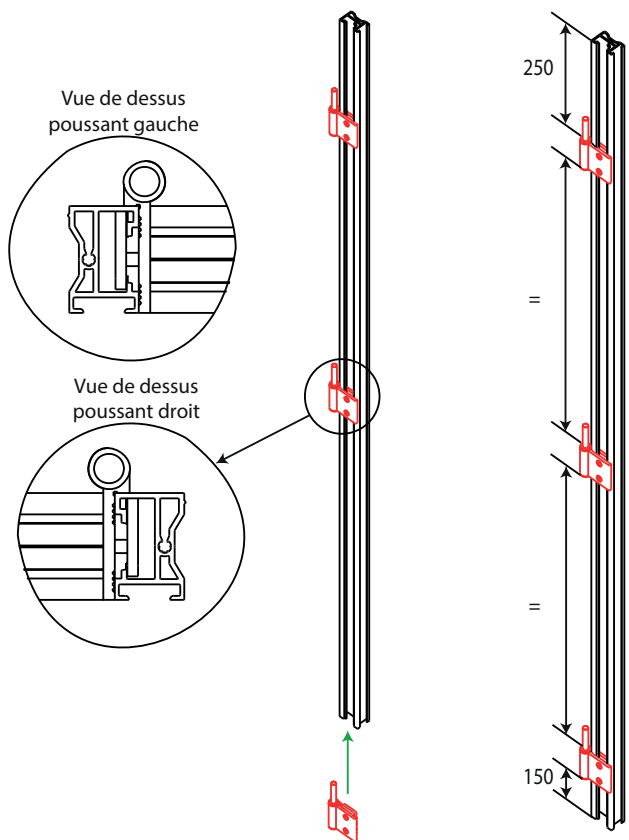

2 - Assemblage DORMANT 26

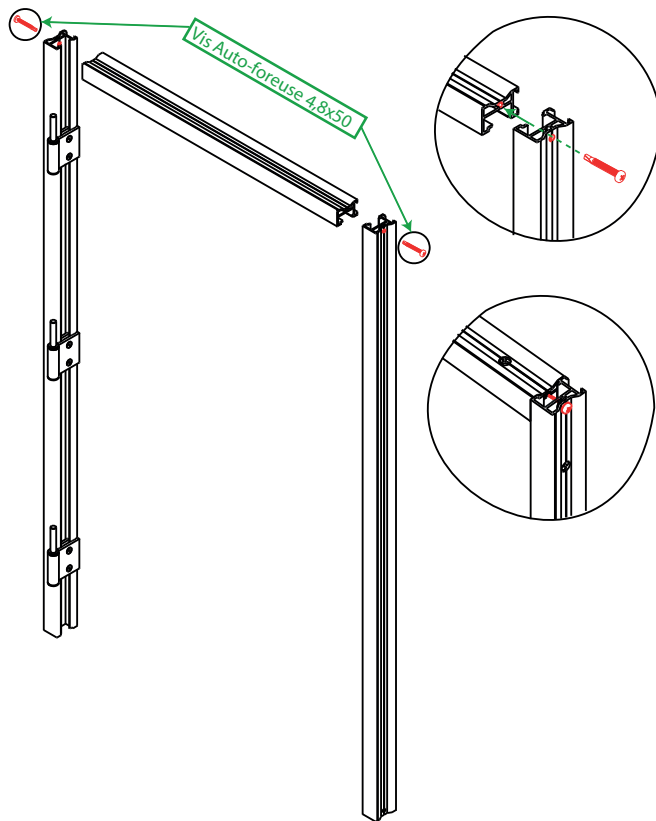

3 - Mise en place de la **gâche** pour la serrure à rouleau avec ou sans pêne

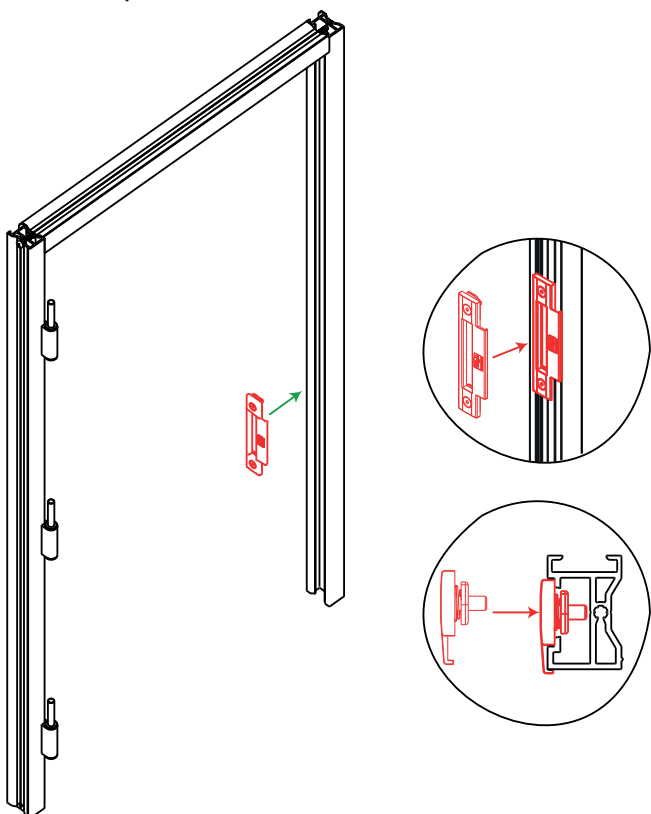

3 - Mise en place de **2 gâches** pour la serrure pêne 1/2 tour + pêne dormant

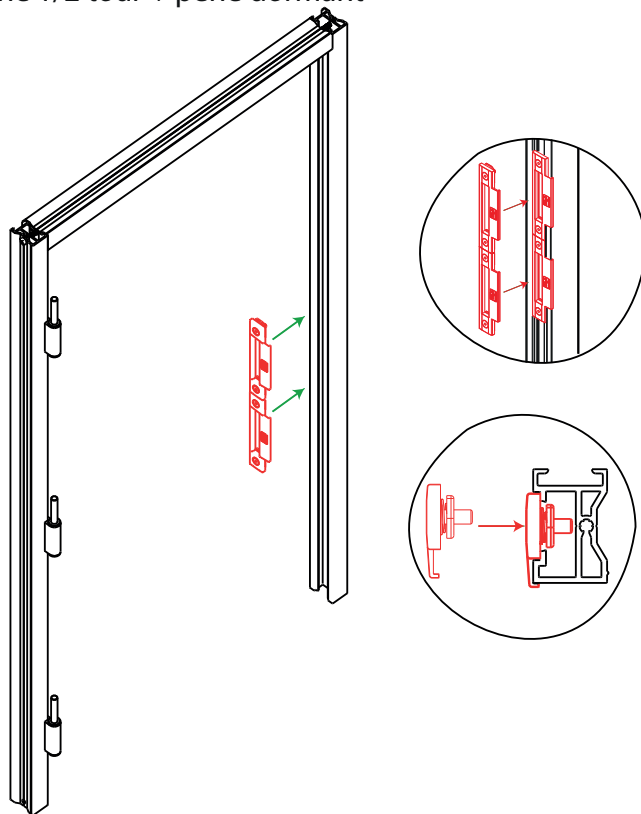



1 - Mise en place **joint de vitrage** sur profil porte 40 et 66

2 - Mise en place **joint de vitrage** sur profil traverse 40

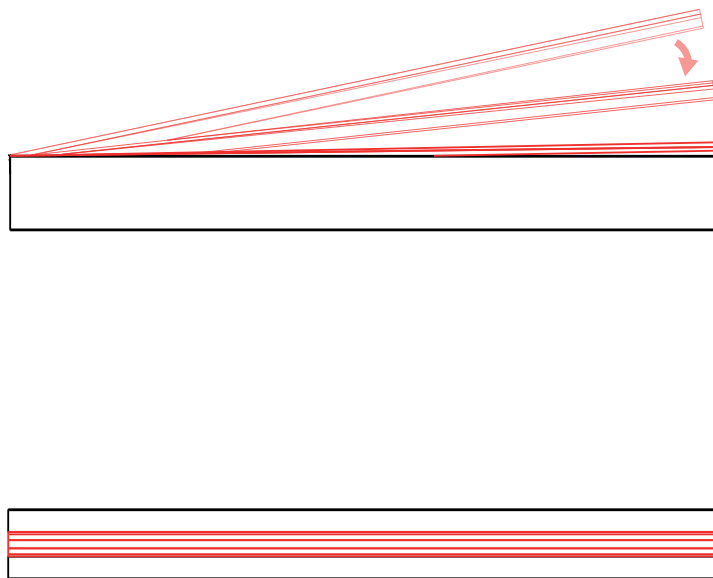
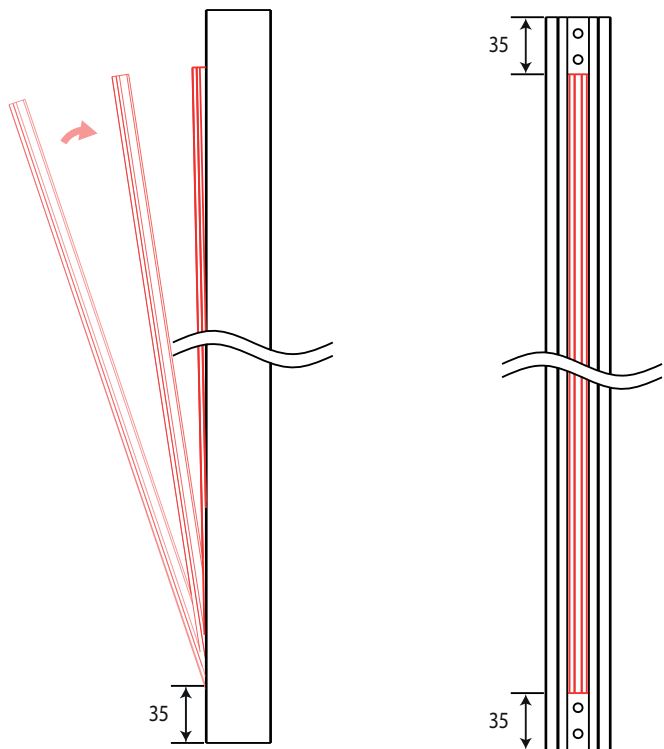

3 - Mise en place des **paumelles supérieures**

4 - Mise en place de la **traverse haute et basse 40**

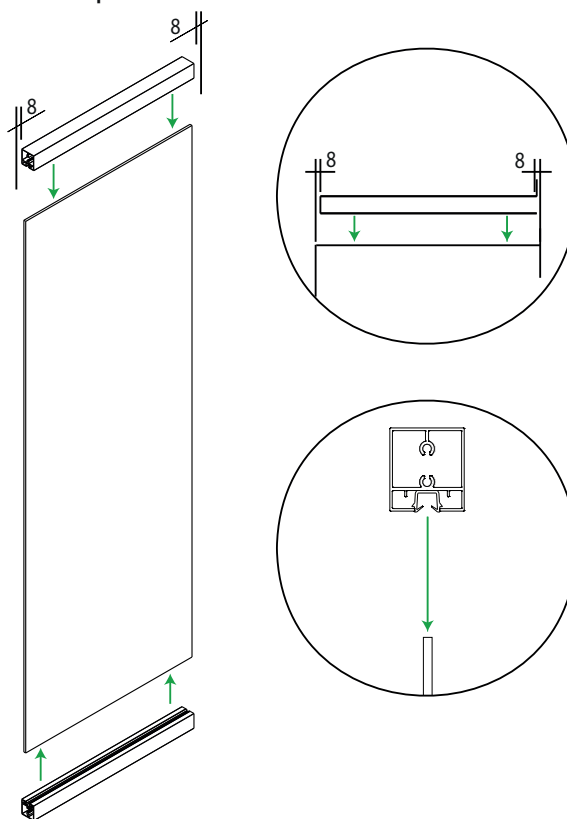
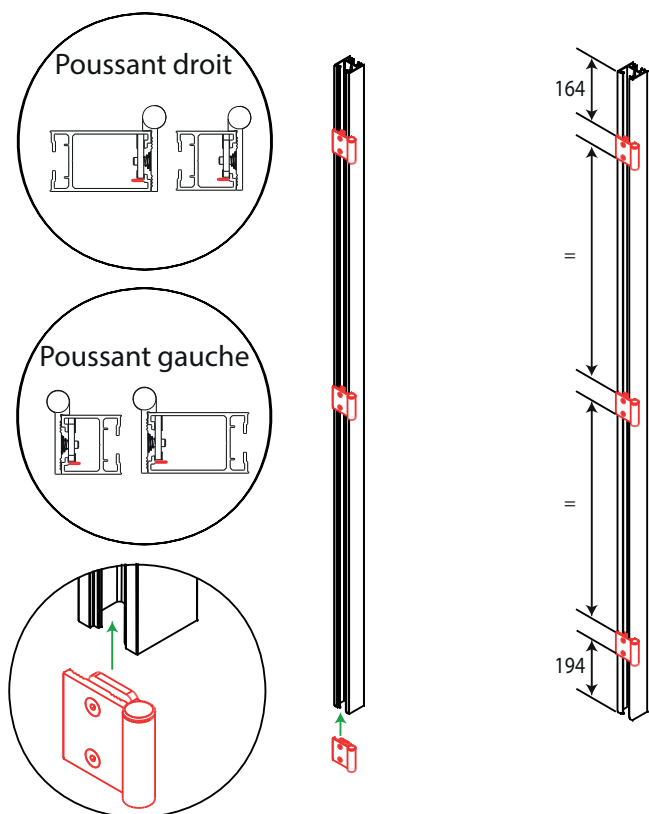



1 - Mise en place des profils porte 40 ou 66

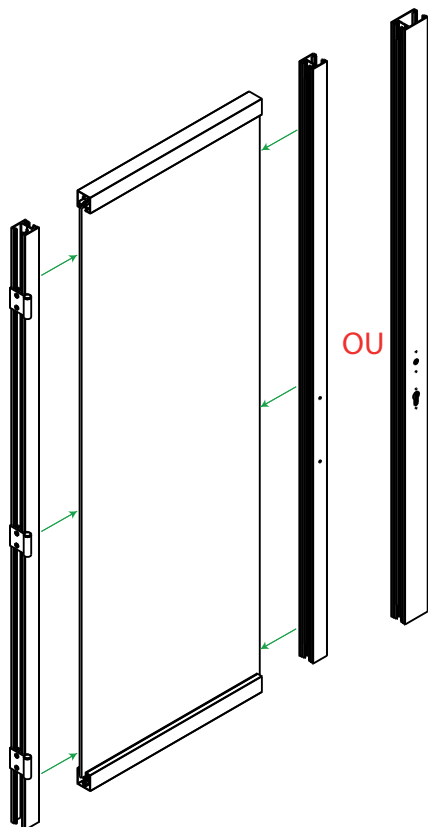

2 - Mise en place des capots d'assemblage porte 40

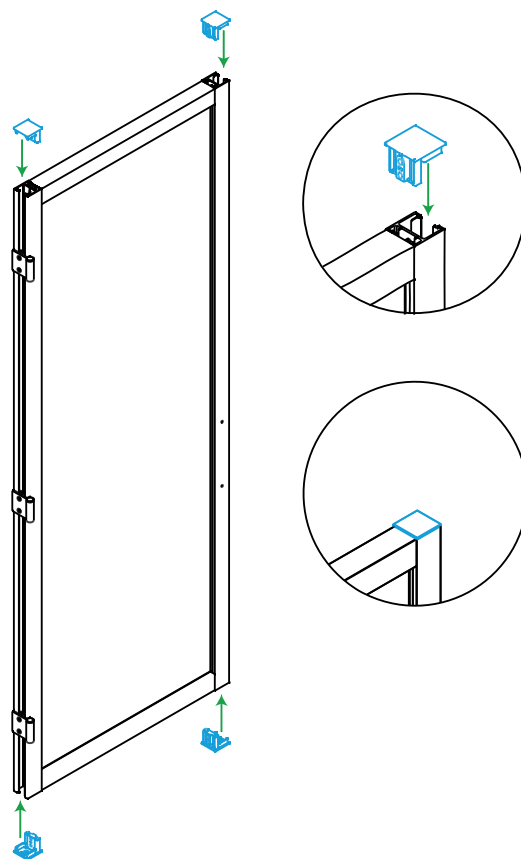

3 - Mise en place des capots d'assemblage porte 40 et 66

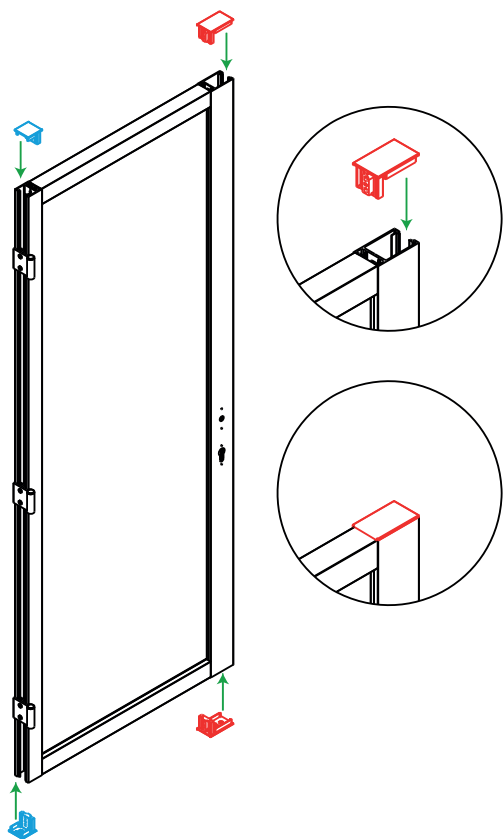

4 - Fixation porte avec vis auto-foreuse 4,8x50 (Embout PH2)

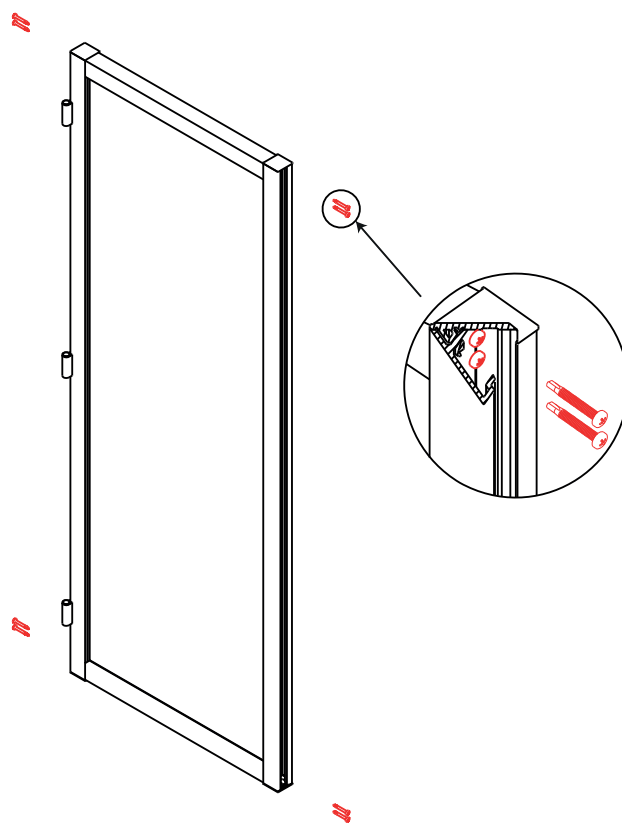



1 - Fixation **poignée de tirage**

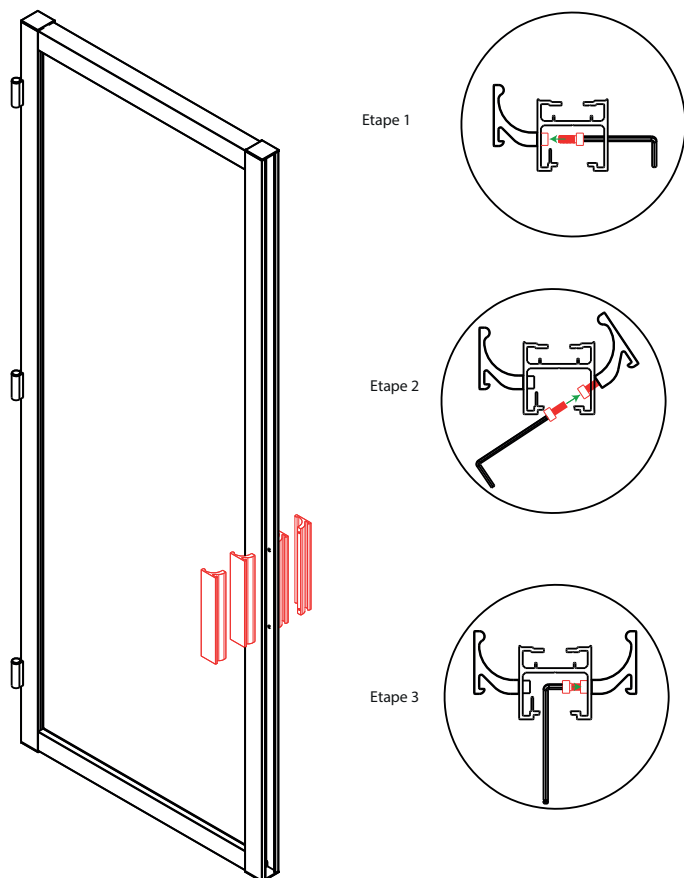

2 - Montage **serrure à rouleau seul**

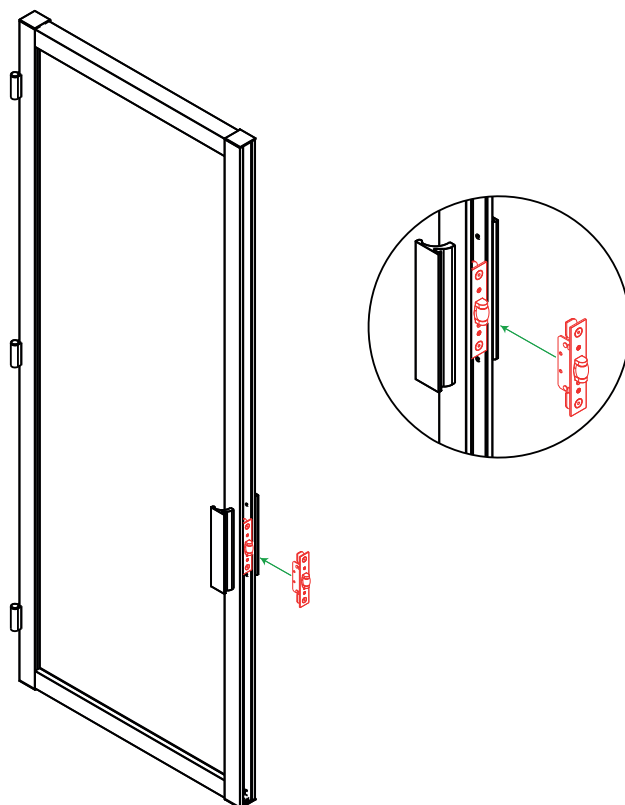

3 - Montage **serrure à rouleau avec cylindre**

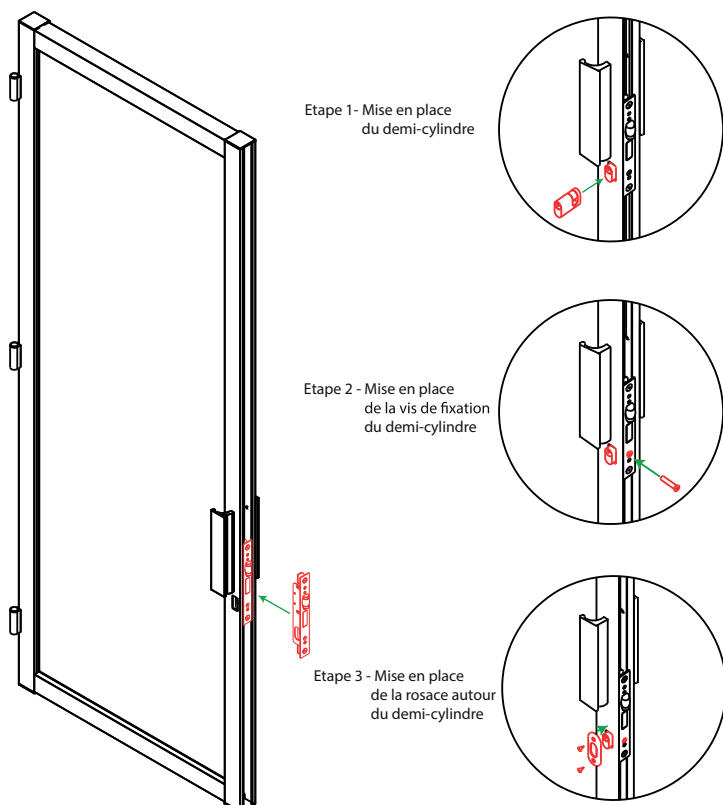

4 - Réglage **serrure à rouleau**

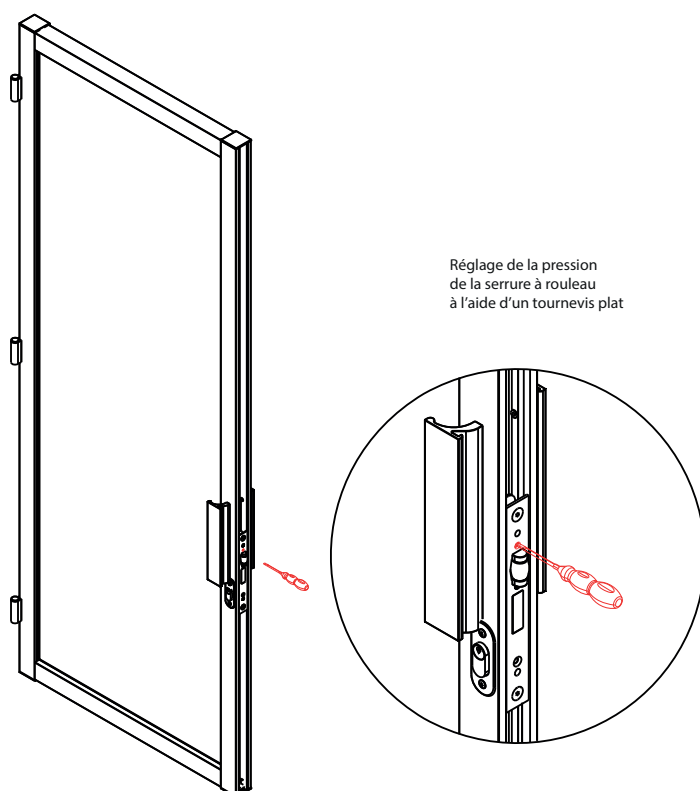



1 - Montage serrure avec pêne dormant

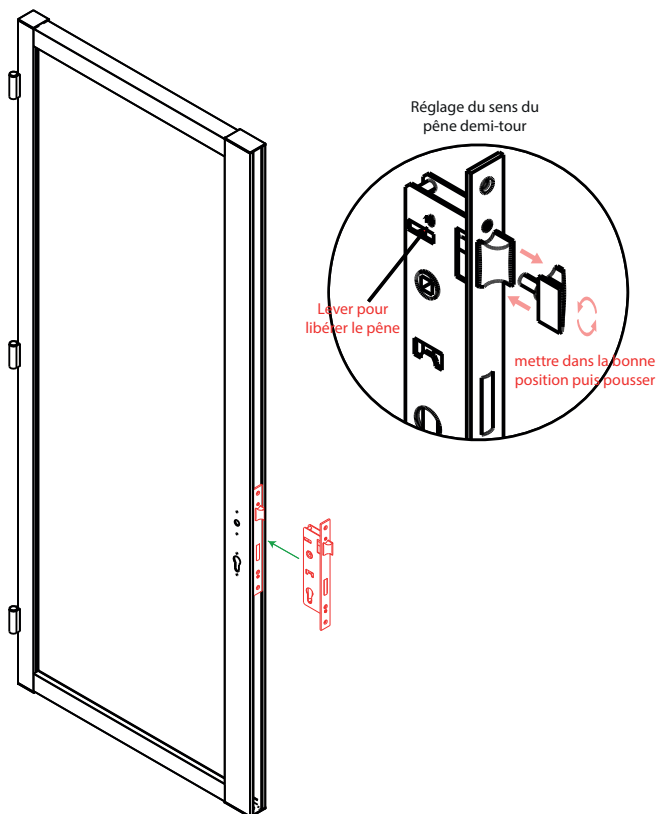

2 - Montage cylindre

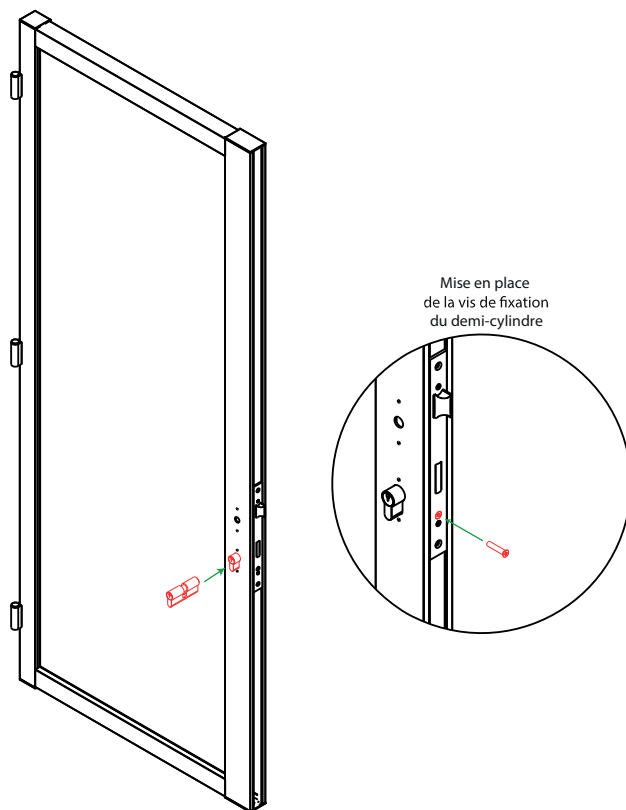

3 - Montage béquilles + sous-rosaces

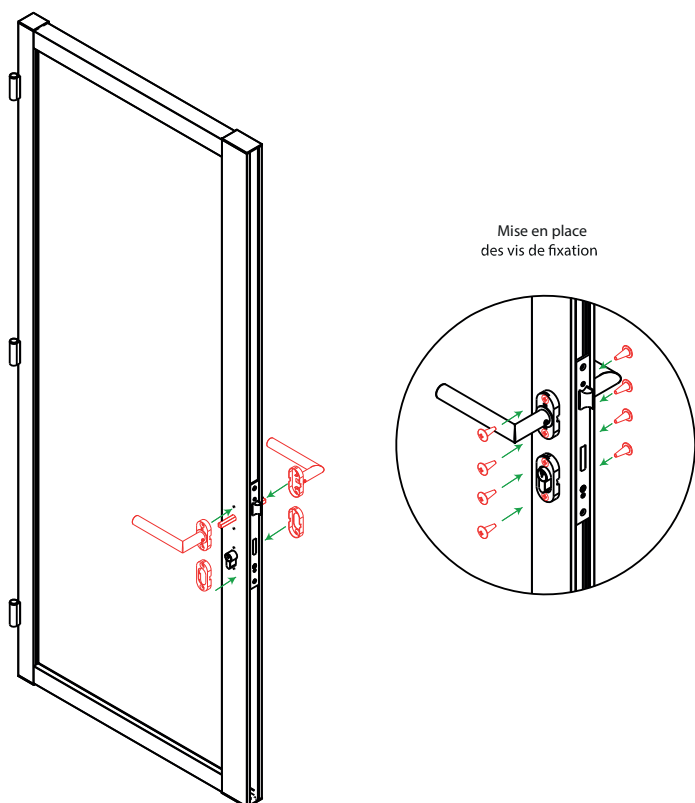

4 - Montage des rosaces

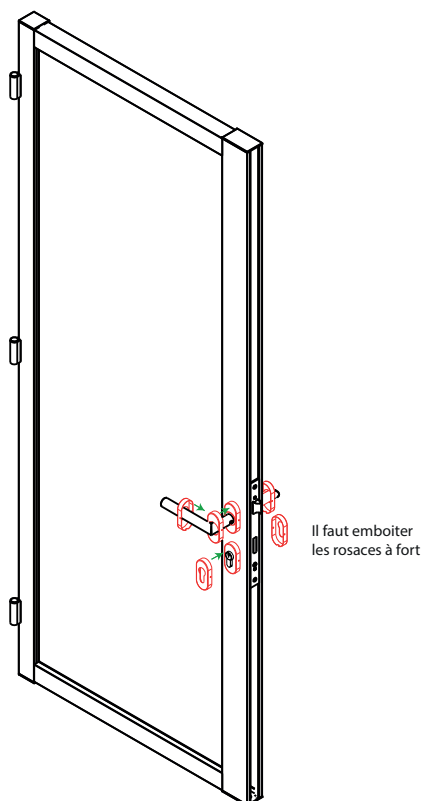



1 - Positionner et fixer l'assemblage **dormant**

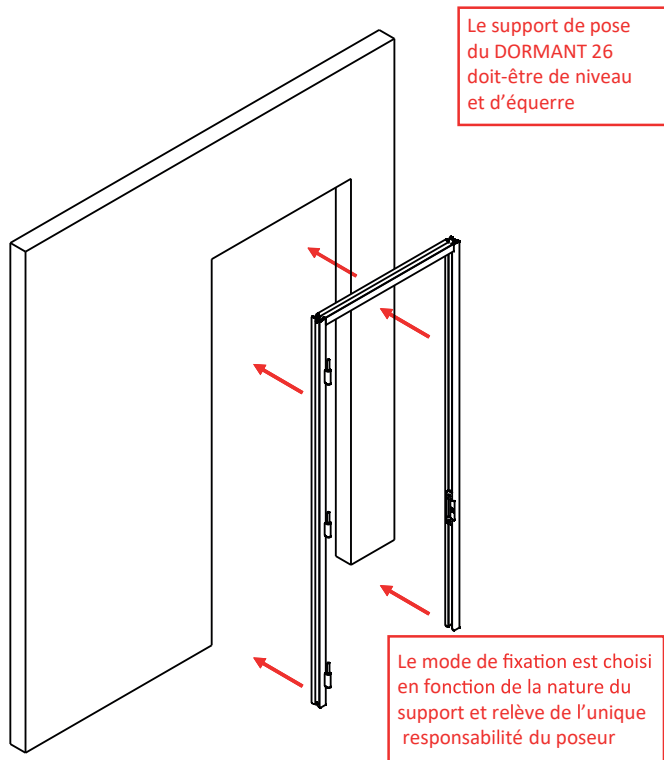

2 - Mise en place des CLIPS dans les **dormants**

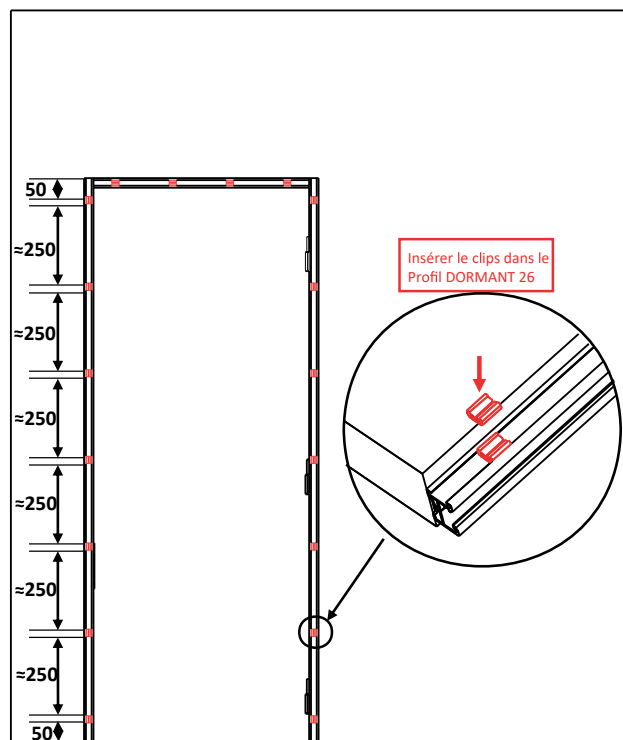

3 - Mise en place du joint **parcloses dormant**

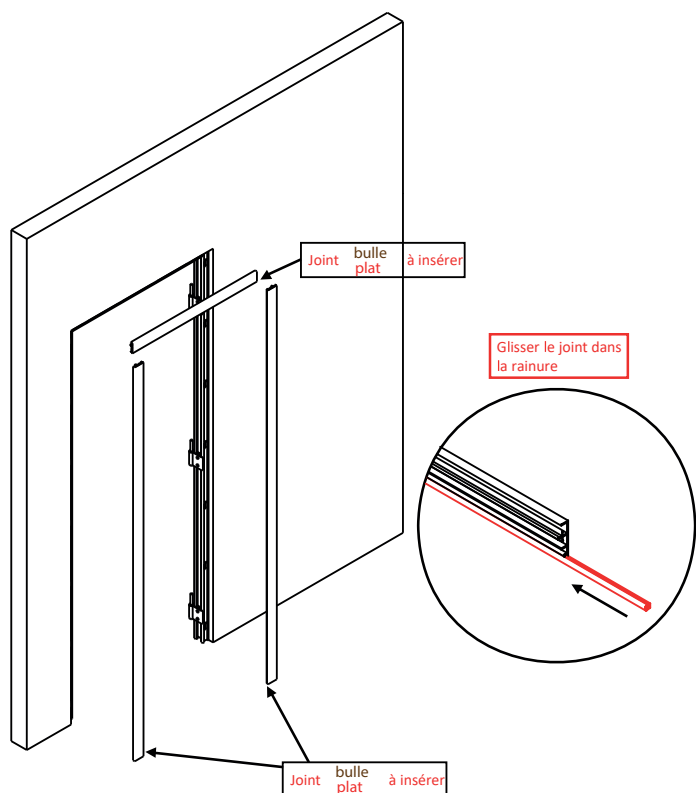

4 - Clipper les **parcloses**

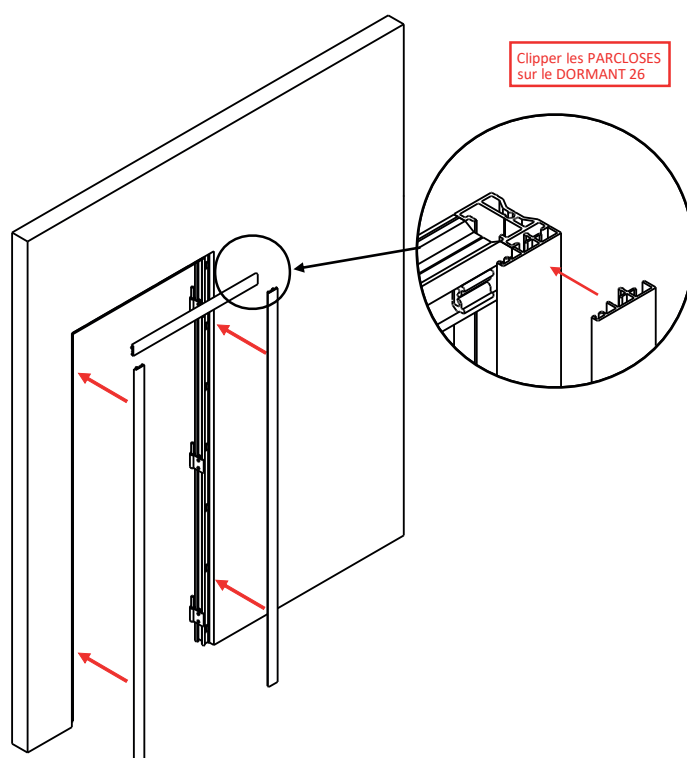



1 - Mise en place de la porte

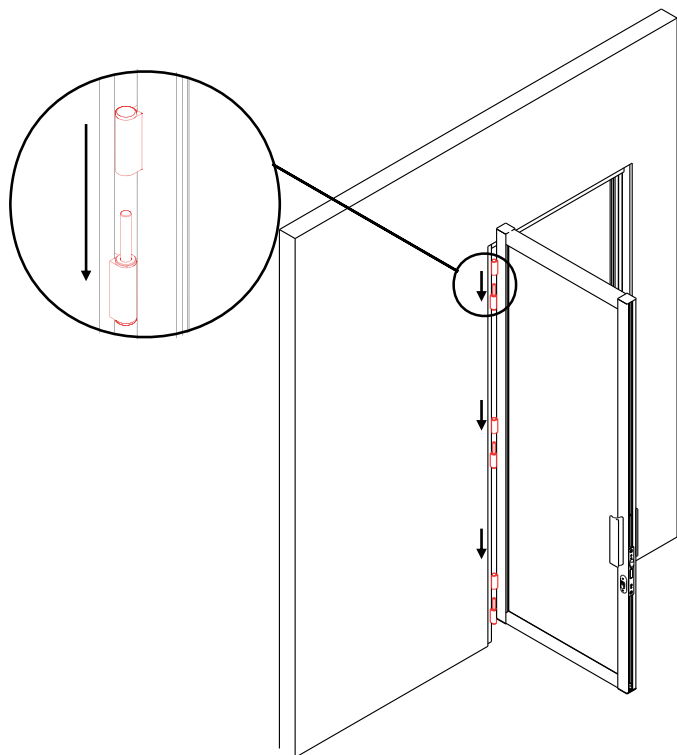

2 - Réglage Porte et Accessoires

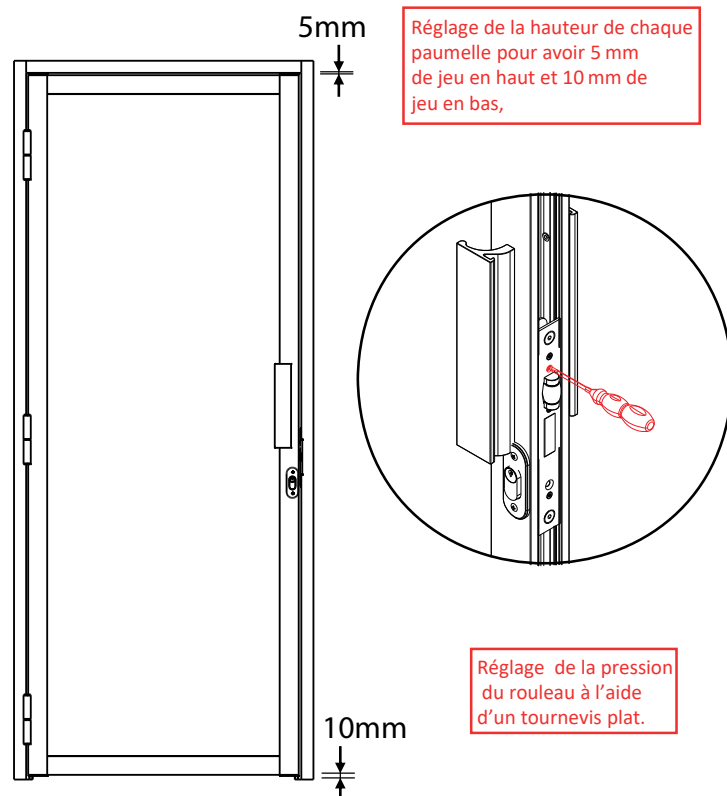

3 - Découpe à mesure des **plats de finition 23** (dormant)

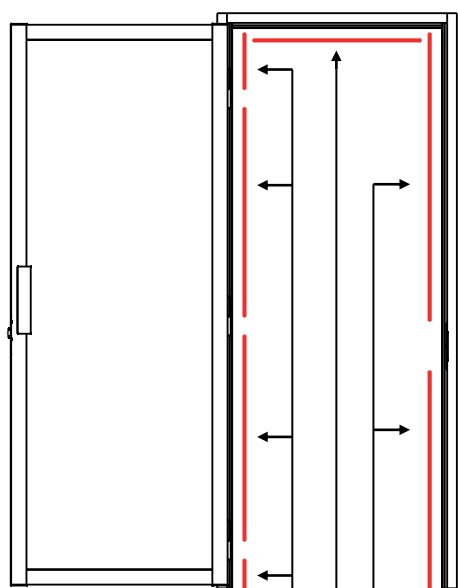

Découpe PLAT DE FINITION 23 pour DORMANT 26

4 - Découpe à mesure des **plats de finition 23** (Porte)

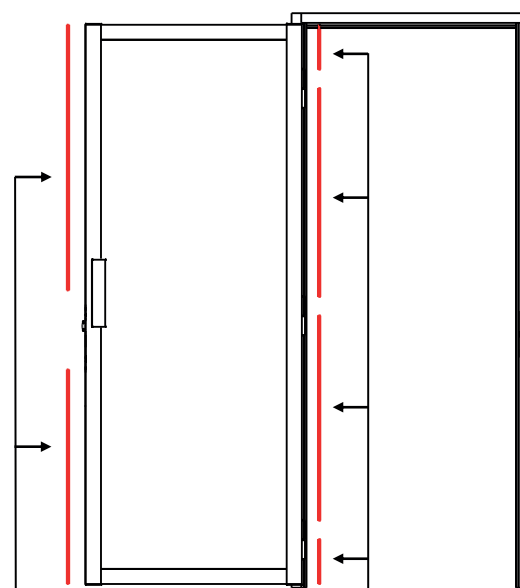

Découpe PLAT DE FINITION 23 pour PORTE OUVRANTE 40



① Perçage CADRE VERRIERE et DORMANT 26 (Ø 5mm)

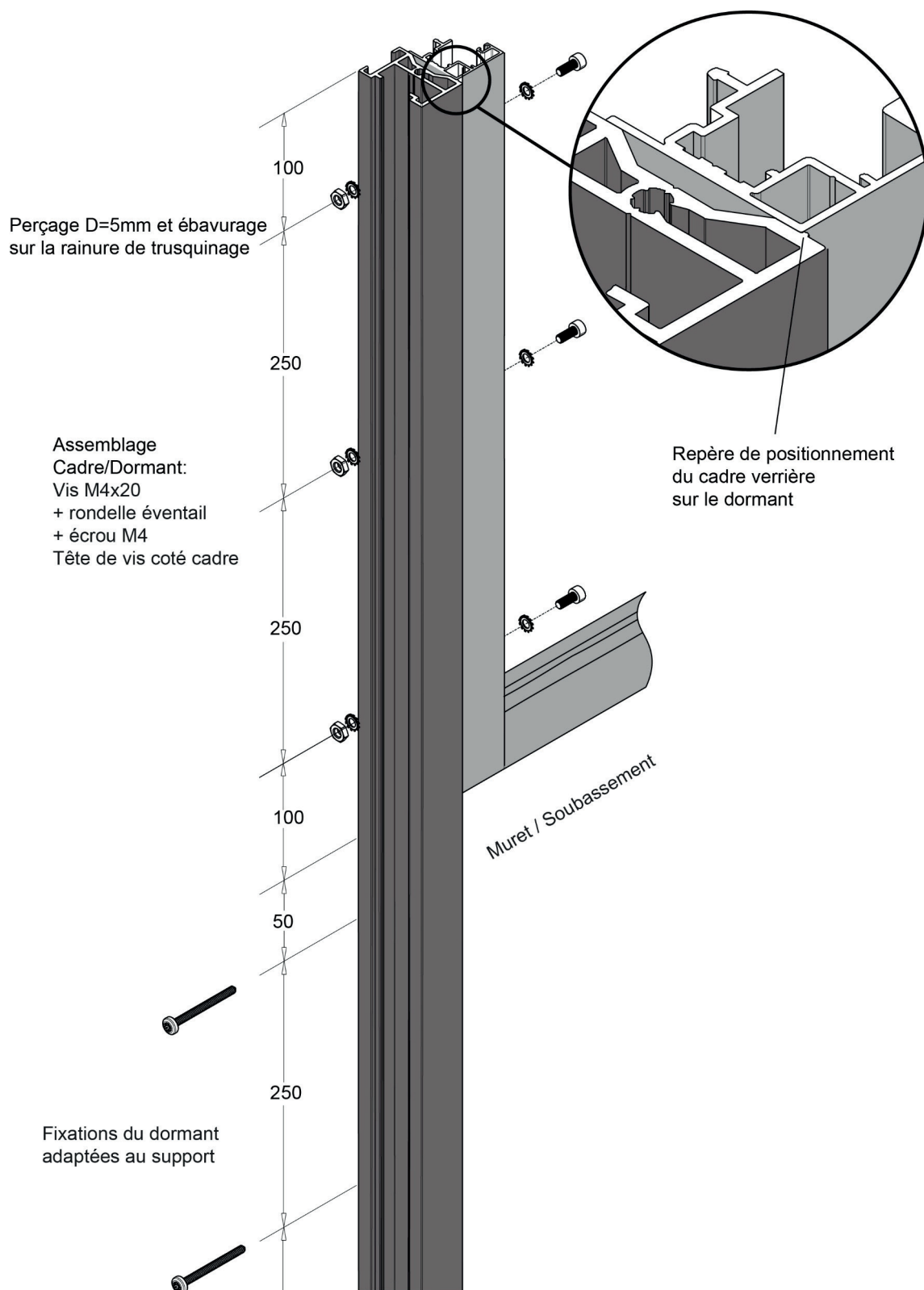





2 Limites et conditions d'installation (préconisées)

